



FEEDBACK



Web Site k3dn.org

Warminster Amateur Radio Club

June 2025

Next Meeting June 5 - Pizza Night and Field Day Prep

General Meeting Minutes May 1, 2025

Call to order at 7:30 PM

Introductions: Attendance 25

Minutes from last Board Meeting: Approved as submitted.

Committee Reports:

- **Treasurer's Report:** Tom K3PLA -through 4/30

- As reported

- **Programs:** Dave K3FTD -

- May - Town Hall

- June – Pizza Night

- **Membership:** Tony W3FLH -

- 102 paid, 94 regular, 3 student; 16 past due

- The club has made the switch to Ham Club Online for record management and communication with members. Cost is about \$110 per year vs. \$1,000 per year for Constant Contact.

- Club members are reminded to log onto HamClubOnline.com to manage their profile information.

- **Public Service:** George N3HBT -

- Memorial Day Parade, Monday May 26th 9 AM to 1 PM will need 10 – 11 hams

- Hole in One Golf Outing on Thursday June 5th 8:30 AM to 1 PM

- Contact George at N3HBT@ARRL.NET of your availability.

- **Classes:** Dave K3FTD/Dan K3GMQ/Tony N3YNH –

- Technician Class is ended; possible General Class planned for the future.

- **VE Testing:** George N3HBT -

- Last session was Monday April 28th, 7:00 PM – 3 new Technician, 2 General

- Next session is Monday June 30th, 7:00 PM, also at the Hamfest on May 4th.

- **Field day:** Herb KB3VMN –

- Planning a Family Picnic – will need volunteers to set up, cook, operate, etc.

- Exploring the possibility of Scout merit badge awards.

- Karl K3KH will be working with Herb on coordinating.

- Still looking for Band captains.

- **Club Station Status:** - George N3HBT -

- Still down due to the condition of the loft. The remodeling is done; however, the club computer and radio equipment needs to be reconnected, tested, etc.

(Continued from page 1)

Old Business:

- **Shed Update:** Herb KB3VMN –
 - Current quote is \$6,570 for a 10' X 14' building with a garage door opening at one end and a single door on the side. No windows. Site preparation included in the quote. A motion was made by the membership, approved and passed.
- **Hamfest:** Tony W3FLH –
 - Set up time has been moved up 1 hour to 2 PM from 3 PM at the Hamfest site.

● **New Business:**

- **No General meeting on Thursday July 3rd** (July 4th is Friday this year)
- **Good and Welfare:** We are looking for someone to cover this important club outreach. If you are interested, please contact the board or me at mcgowan2@...

Meeting adjourned at 8:07 PM

No presentation; instead, general discussions and fellowship.

100m Robert C. Byrd Green Bank Telescope By Bill, K3ZMA

<https://greenbankobservatory.org/about/telescopes/gbt/>

The Robert C. Byrd Green Bank Telescope, or GBT, is the world's premiere single-dish radio telescope operating at meter to millimeter wavelengths. Its enormous 100-meter diameter collecting area, its unblocked aperture, and its excellent surface accuracy provide unprecedented sensitivity across the telescope's full 0.1 – 116 GHz (3.0m – 2.6mm) operating range.

The single focal plane is ideal for rapid, wide-field imaging systems – cameras. Because the GBT has access to 85% of the celestial sphere, it serves as the wide-field imaging complement to ALMA and the EVLA. Its operation is highly efficient, and it is used for observations about 6500 hours every year, with 2000-3000 hours per year available to high frequency science.

Part of the scientific strength of the GBT is its flexibility and ease of use, allowing for rapid response to new scientific ideas. It is scheduled dynamically to match project needs to the available weather. The GBT is also readily reconfigured with new and experimental hardware, adopting the best technology for any scientific pursuit. Facilities of the Green Bank Observatory are also used for other scientific research, for many programs in education and public outreach, and for training students and teachers.

Quick Facts about the GBT:

- The GBT is running observations roughly 6,500 hours each year, more than any other observatory
- For each hour of time available for science on the GBT, roughly 3-4 hours are requested
- More than 600 individual scientists and students proposed to use the GBT within the past year
- More than \$25,000,000 has been invested in the GBT in the past five years by colleges, universities, the NSF, and the state of West Virginia
- The surface of the GBT is perfectly smooth to a noise level of 260 microns (5 human hairs)
- The pointing accuracy of the GBT is 2 arc seconds, able to resolve a quarter at 3 miles
- The GBT weighs almost 17 million pounds and stands over 485 feet above ground level. The GBT's collecting area is 2.34 acres

(Continued on page 3)

(Continued from page 2)

and its diameter is 300 feet

- The GBT operates 24 hours/day, 362 days/year

The operational funding provided by the NSF is approximately 0.1% of the NSF astronomy budget

More detailed Info

<https://greenbankobservatory.org/portal/gbt/instruments/>

Image Gallery

Click the image below to go to our GBT image gallery on Flickr

<https://www.flickr.com/photos/greenbankobservatory/albums/72157664344856218>

The following was submitted by: Bob, WA3PZO, Trustee WM3PEN

13 Colonies Special Event July 1 – 7

Recognizes Ken Villone, KU2US, Event Founder

In just a few weeks, one of the most popular summer operating events kicks off – The 13 Colonies Special Event. Now in its 17 year the event has grown from Special Event Stations making approximately 12,000 contacts to last year making 292, 496 contacts around the world. The Event runs from July 1 9:00 AM -July 7 Midnight Eastern (July 1 – 1300 UTC – July 8 – 0400 UTC).

This year Event organizers are recognizing the 13 Colonies Special Event founder Ken Villone, KU2US, who is passing the torch on to Tony Jones, N4ATJ. For the past 16 years Villone has lead the Event by working with state and bonus station coordinators. Then after the event he would print out individual certificates for thousands of people who made contact with the special event stations.

The Special Event consist of one station operating in each of the 13 Colonies (K2A – K2M) and three bonus stations (WM3PEN – Philadelphia, GB13COL – England, TM13COL – France) each representing their city, state, or countries role in America's Colonial period.

Villone describes how the event got started:

“I had just finished participating in the ARRL Sweepstakes in 2008, and remarked how fun it was. I could not figure out why there were not more of these type special events on the air? So I decided to try my luck and create one for one year only to see what happens and to have some fun. I knew we had to offer a special QSL card and/or certificate plus have on hand a printer and supplies. The hard part was deciding what the event would commemorate and when to do this. I needed a theme that ALL could relate to! Also the event would have to be the type with multiple event stations involved, like the ARRL Sweeps.

Then it hit me! 13 Colonies states, during the 4th of July week and offer a certificate with the theme for the year,.I made sure the theme was different each year with a different certificate design, to make it interesting and to also make the cert collectable. The theme would highlight some event or thing connected to the American Revolution. The event was held July 1st to the 4th, 2009, 4 days with no advertising except on QRZ. I had a hard time getting 13 different Ops, one from each Colony state but it worked out. All in all it was a success! We did over 12,000 contacts the first year. I decided we have a good thing going so I recruited another Op from each state and ran the event the next year in 2010. We did over 32,000 contacts in 2010, and had 26 state operators total. There was a 13 Colonies special event in 1962 but only lasted one year, according to my research. (I was 13 years old).”

Ham Radio operators and SWLs can participate in the event. Complete information about the call for each colony station and the bonus stations can be found on the event website 13colonies.us and they can follow us on Facebook – 13 Colonies Special Event Community. Stations need only make one contact with one of the participating stations or they can go for a Clean Sweep and work all 13 Colony stations and the 3 bonus stations. Each station offers a special QSL card for the event as well as a different certificate each year. Operators can keep an eye out for the special event stations can keep an eye out for them by watching many of the dx spotting networks such as DXSummit.fi.

(Continued on page 4)

WA4YWM BLOG GNU Radio

This month I decided to get a little more technical. This blog is intended for those of us who are interested in Software Defined Radio and producing the software in the Software part of the SDR. I also hope to present this subject to those who may be wondering what GNU Radio is and a little bit about how it is implemented. There is no intent to get into the details of producing the software. If there is some interest I can cover that in a future article.

The example I am presenting is used on my Softrock SDR platform. The Softrock is hardware that I have been working with for quite a few years and it has been an excellent test bed for my adventures in SDR. It is very inexpensive and has many resources online. If you are interested in getting into the Softrock world, go to:

<https://softrock40.com>

and check it out. A transceiver kit can be purchased for \$170 that will give you a start at 1W out.

If you want to take things up to a higher level check out:

<https://rfpowertools.com/products/iq32-5w-hf-sdr-transceiver>

This transceiver is based on the Softrock design and a now obsolete design called the Mobo which I also am using giving you a 5W transceiver.

I will be showing you my implementation of SSB in GNU Radio for the Softrock. I also have a functional FT8 design which I am finishing up (if there is such a thing as being finished – it is a work-in-progress). First, a couple of questions and answers from the GNU Radio web site.

What is GNU Radio?

GNU Radio is a free & open-source software development toolkit that provides signal processing blocks to implement software radios. It can be used with readily-available low-cost external RF hardware to create software-defined radios, or without hardware in a simulation-like environment. It is widely used in research, industry, academia, government, and hobbyist environments to support both wireless communications research and real-world radio systems.

What is Software Radio?

The Wikipedia page on Software Radio provides an excellent overview. In brief, a software radio is a radio system which performs the required signal processing in software instead of using dedicated integrated circuits in hardware. The benefit is that since software can be easily replaced in the radio system, the same hardware can be used to create many kinds of radios for many different communications standards; thus, one software radio can be used for a variety of applications!

Now to the Good Part

The block diagram below shows the entire system. The system is controlled by a Raspberry Pi with two sound cards providing the I/O. The StarTech card is the I/Q interface for the transceiver. The Sabrent card is the mic and speaker interface.

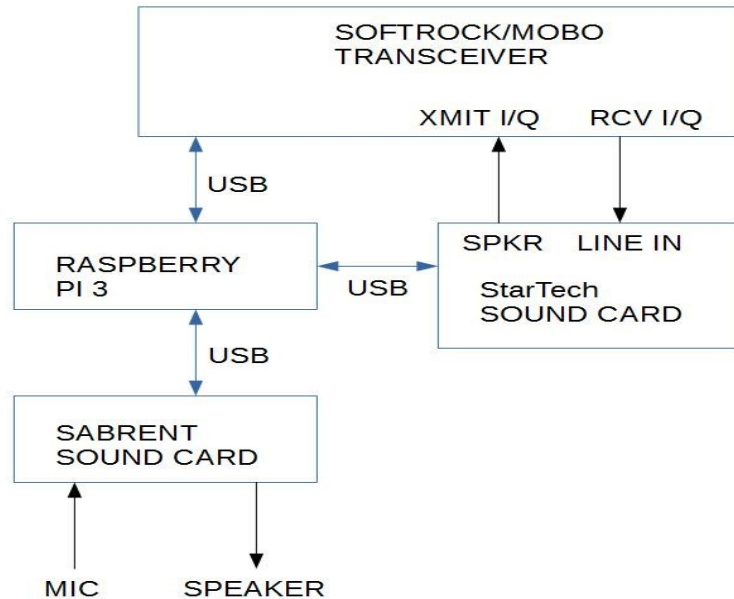

What follows are my three parts of the design: the top block, the receive block and the transmit block.

The top block (shown on the following page) is the overall controlling software block. It is really fairly simple. Most of the blocks shown are developing the user interface – the buttons, text entry and displays that you see in the following pages. Keep in mind that each block is a piece of software written in C++ or Python. The only block that I had to create myself is the Freq block written in Python. All the other blocks are part of the GNU Radio library.

The Receive Block and the Transmit CESSB block are the meat of the design since they provide all the demodulation and modulation of the signals. The Selector block provides for selection of the receive signals or the transmit signal to be shown on the respective displays.

Below you can see the screen that is displayed containing the complete user interface. Note that the frequency selected is 7.04 MHz and you can see the signal being input is at 7.04 MHz. The image is in the noise at better than 40 dB down from the received frequency.

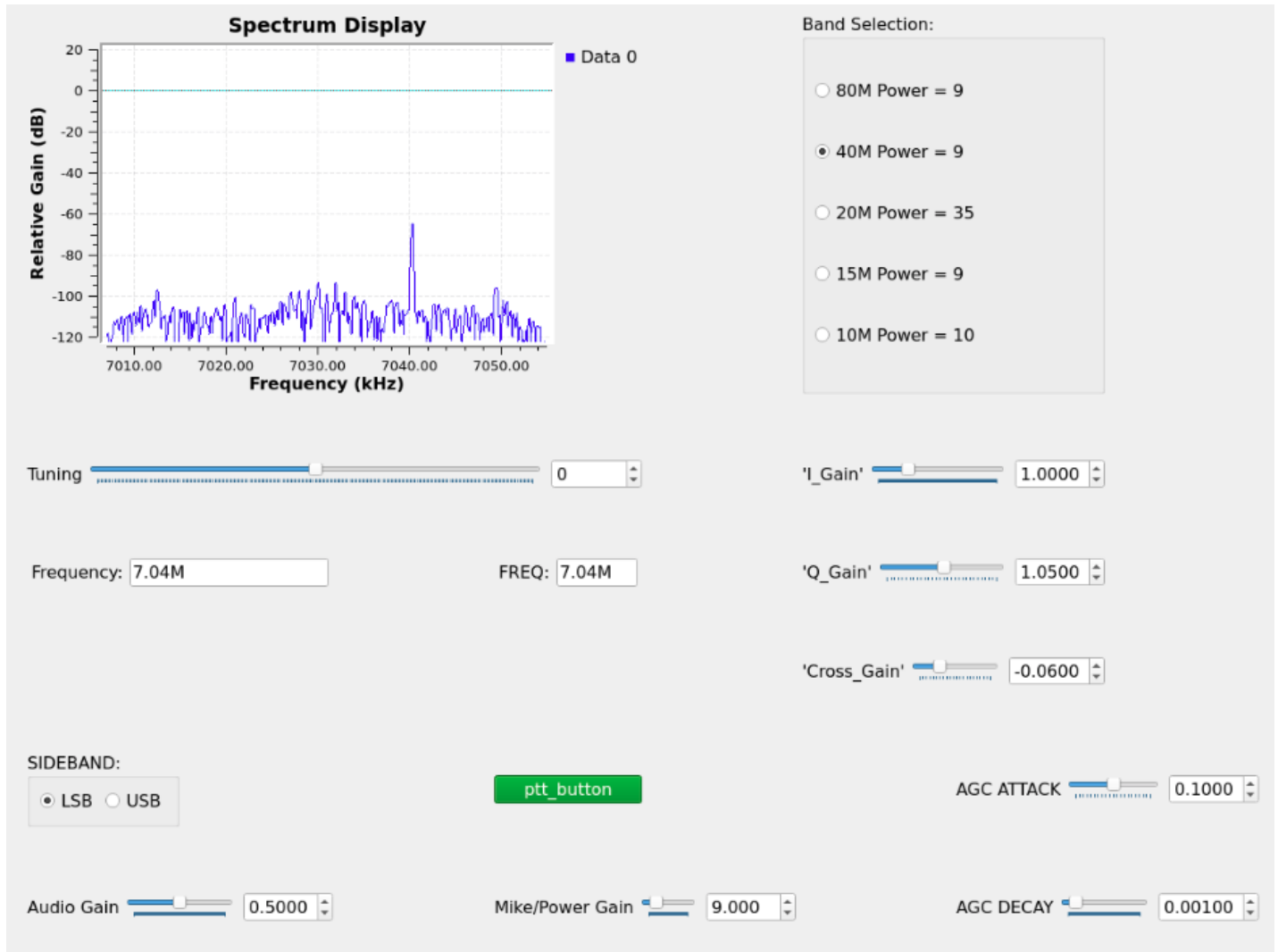

Here is the Transmit Block and the associated display. The only two differences in this display from the one for Receive is that the ptt_button has been clicked as shown in red and the Spectrum Display shows the lower sideband transmitted signal at 7.25 MHz.

The Transmit Block shows the mic input from the Sabrent sound card on the left. This input is processed through the CESSB (Controlled Envelope SSB) blocks ending with the input to the StarTech sound card which then drives the transmit stage of the Softrock.

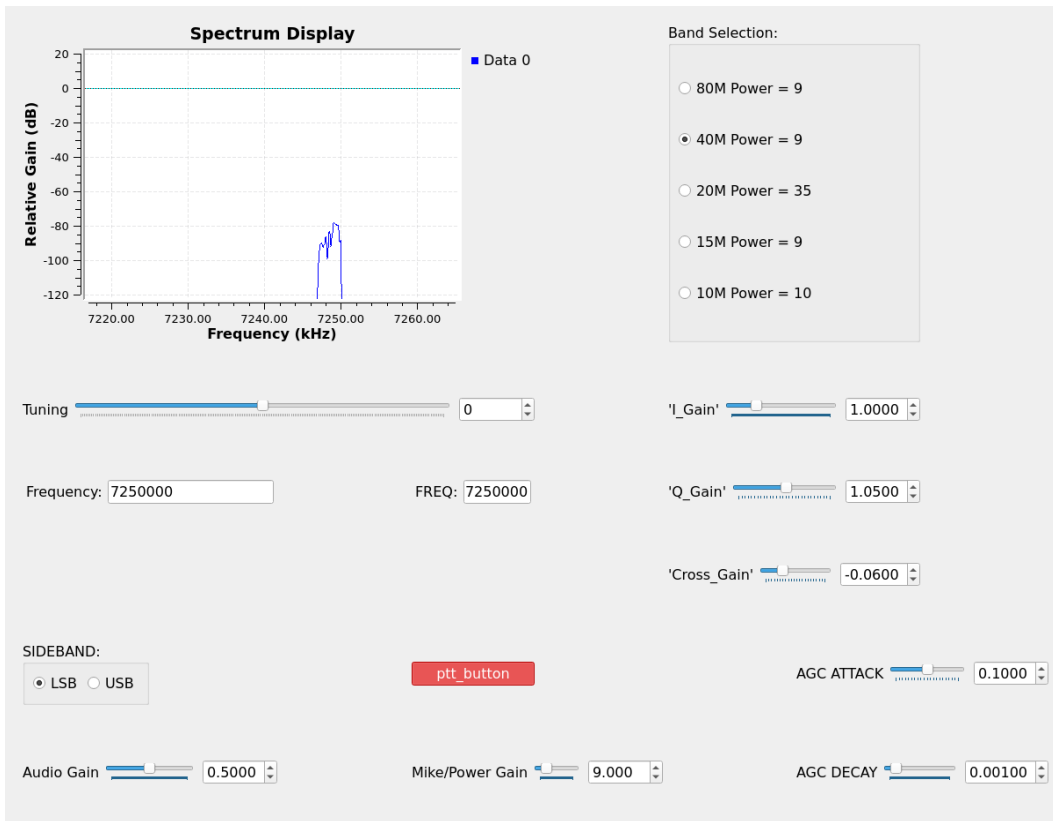
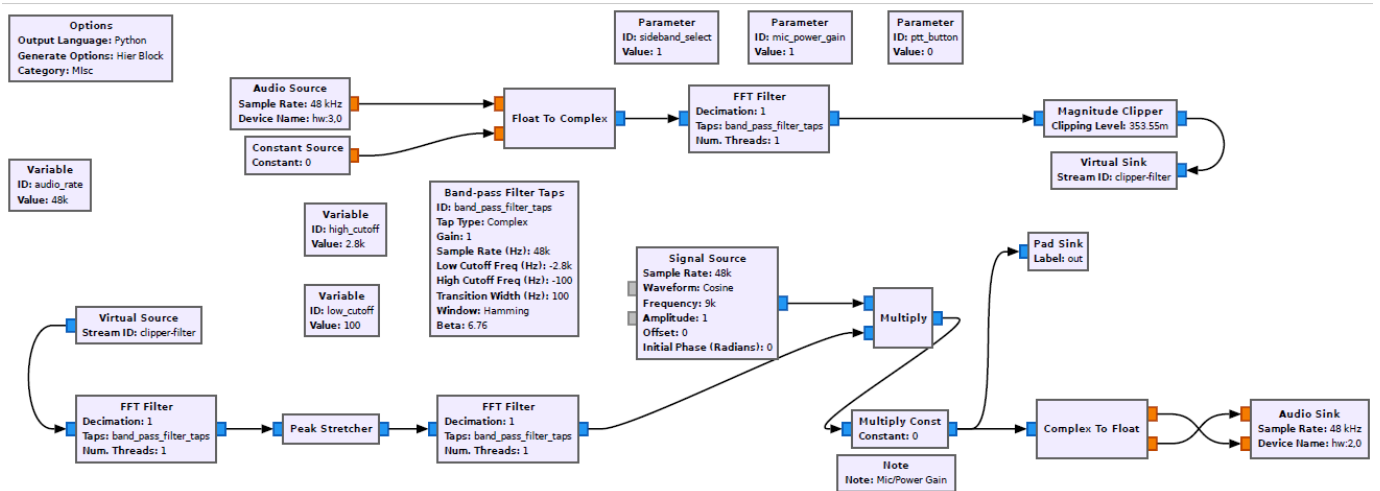

So there you have it – a complete 5 band transceiver built without any soldering required (except for the Softrock hardware for input and output).

See you next month.
73, Jim WA4YWM

ARRL Awards Phil Karn, KA9Q, with Mary Hobart, K1MMH, Medal of Distinction

ARRL has honored Phil Karn, KA9Q, with the Mary Hobart, K1MMH, Medal of Distinction. He was presented the honor at the ARRL donor reception on May 15, 2025, at the National Museum of the United States Air Force on Wright-Patterson Air Force Base near Dayton, Ohio. The annual event — in the museum's Presidential Gallery, surrounded by retired Air Force One aircraft — kicks off ARRL's activities around Dayton Hamvention®.

Karn is a graduate of Cornell University and Carnegie Mellon University with degrees in Electrical and Computer Engineering and has retired from a technology career including Bell Labs, Bellcore, and Qualcomm. He is co-founder of AMPRnet, is founder and past-President of Amateur Radio Digital Communications (ARDC), a private foundation that exists to support amateur radio and digital communication science and technology through grants and scholarships, and the management of 44Net. Karn continues to serve on the ARDC Board of Directors. The work of ARDC has contributed approximately \$30 million to amateur radio since 2020.

Karn has been licensed since he was 15. "It's been a major factor in my life, directly and indirectly," he said. Karn views amateur radio as a creative outlet. "I'm an engineer, so I need an outlet for my technical ideas. I'm retired, so amateur radio now fulfills that need. It's very gratifying to see others using your ideas and works," said Karn.

Karn's technical contributions to advance the Amateur Radio Service drive his dedication to the future of education through ham radio. He envisions education having a greater role in amateur radio in decades to come. "Ham radio has always excelled at individual self-learning, but it could do so much more. I'd really like to see the many technical tinkerers outside ham radio join us. I'd like to see much more amateur radio in formal education. HamSCI and the many university small satellite groups are good examples but there could be so much more. Hams will continue to create new technology, usually by working in academia and industry but also as individuals," he said.

Mary Hobart, K1MMH, was ARRL's first Chief Development Officer. She passed away in 2021. The medal named in her honor is given to those individuals or couples who have inspired our small community to reach higher with their own philanthropic support of ARRL and amateur radio. In 2023, ARRL honored Michael "Mike" D. Valentine, W8MM (Silent Key), and his wife Margaret "Peg" Valentine with the inaugural Hobart Medal.

Karn hopes others follow his lead in contributing to the future of amateur radio. He says there's no real secret to being a leader — just participate. "The world is easier to change than you might think, but it takes time and persistence. When I was young, I often got frustrated by what seemed like sluggish change, but it will happen. Even if you don't have much time for ham radio when you are busy with your career, try to stay connected with other hams. Encourage your friends and family to become hams. Attend club meetings and dinners. It will pay dividends."

Attendees at the reception also heard a keynote address from Dr. Ed Snyder, W1YSM, about his ARDC-funded "Marconi" program, which promotes strengthening of amateur radio clubs by encouraging very active clubs to mentor, or "Elmer," less active clubs. Marconi, in this case, is an acronym for Motivating Amateur Radio Clubs to Open New Initiatives. More information is available at www.arrl.org/marconi.

Courtesy ARRL Newsletter



ARRL CEO David Minster, NA2AA, with Phil Karn, KA9Q at the ARRL Donor Reception

Elmer's Corner

Welcome to Elmer's Corner. This will be a section where hams can request help with ham related issues. Our goal is to match someone with experience with the issue you are having in order to resolve your problem. This is intended to cover all aspects of ham radio:

Equipment Software Antennas Operations

Send the editor an email detailing the issue: wa4ywm@comcast.net.

2025 Contest Calendar

June

7-8 [International Digital Contest](#)

1800 UTC Saturday, ends 2359 UTC Sunday

14-16 [June VHF](#)

1800 UTC Saturday, ends 0259 UTC Monday

21 [Kids Day](#)

1800 UTC through 2359 UTC

28-29 [Field Day](#)

1800 UTC Saturday and running through 2059 UTC Sunday

July

12-13 [IARU HF World Championship](#)

1200 UTC Saturday and runs through 1159 UTC Sunday

19-20 [North American QSO Party RTTY](#)

1800Z, Jul 19 to 0559Z, Jul 20

QSO Parties

Kentucky 1300Z, June 7 to 0100Z, Jun 8

West Virginia 1600Z, Jun 21 to 0400Z, Jun 22

V.E. TEST LOCATIONS

Confirm all information, in advance, with the contact person. Licensed applicants must bring the original, and one photocopy of their license. All applicants, including children, must bring two forms of positive ID. Also bring the original, and a copy, of any Certificate of Successful Completion needed to prove current status. The ARRL VEC'S 2024 test fee is **\$15.00**.

Warminster Amateur Radio Club, Monthly, Last Mon. 7:00 pm at the Wilson Senior Community Center 580 Delmont Avenue Warminster, PA 18974 George Brechmann (215) 443-5656.

Atco, NJ, The fourth (4th) Tuesday of each month, at 7 p.m. Winslow Township Senior Center, 33 Cooper Folly Road, 08004-2603.

Mark (K2AX) jtra@comcast.net

Levittown, PA, Monthly, 1st Wednesday at 6:30. Levittown Library - Ben Johns, K3JQH, 215-657-5994

Telford, PA, RF Hill ARC. Indian Valley Library. Held the third Monday of odd months (January, March, May, July, September, November)

Contact: Jim Soete 215-723-7294
wa3ylq@arrl.net.

Philadelphia, PA, Testing is done on the 3rd, non holiday Monday of the month at the Giant Supermarket, 315 York Rd., Willow Grove, 19090 at 6:30 PM in the Community Room. For further information contact James McCloskey at jmccloskey@msn.com and by phone 215-275-2979.

Lansdale, PA Testing on the fourth non-holiday Thursday of the month starting at 7:00 PM. The Lansdale Library Community Room Vine St. and Susquehanna Ave. Lansdale, Pa. Registration is required 48 hrs. or more before the scheduled exam date. If there are no registrations the scheduled exam date will be canceled. NO WALK-INS. You can register by contacting:
Olaf N. Markert - Phone (610) 517-5074, E-mail w3pa@arrl.net
Alt Contact: Jim, 610-287-5630

➤ ATLANTIC DIV. HAMFESTS

➤ 2025



June 15 - [Baltimore Amateur Radio Club Father's Day Hamfest](#)

Arcadia Carnival FairGrounds

16020 Carnival Ave.

Upperco, MD 21155

<https://w3ft.com/hamfest/>

June 21 - [Bloomsburg Hamfest](#)

Lime Ridge Community Center

6405 4th Street

Lime Ridge, PA

<https://www.qsl.net/cm-arc/hamfest.htm>

July 5 - [Firecracker Hamfest](#)

Harrisburg Postal Employees Picnic Grounds

1500 Roberts Valley Road

Harrisburg, PA 17101

<http://www.w3uu.org>

CLUB INFO

PUBLIC SERVICE

Golf Outing on Thursday June 5th
Contact George N3HBT

CLUB STATION

The WARC club station is open to anyone with an interest, on the first Thursday of the month (meeting night) between the hours of 6:30 and 7:30 pm. with the exception of the December dinner meeting. For further information, call George Brechmann N3HBT at 215-443-5656.

WARC ALUMNI MEMBERSHIP

An Alumni membership category is available for WARC members who are unable to attend meetings and club activities on a regular basis because of health considerations, travel impediments, or other hardships. Dues for the Alumni membership are \$12.50 annually and are approved by the Board. Please contact the Membership Committee for more information if interested."

ATTENTION MEMBERS

The Membership Committee can provide Club badges. Two types are available: an engraved plastic call sign and name badge for \$8 or a free, laminated plastic, photo ID badge/card. The photo id badge is included with your membership. Pictures for the club badge will be taken before club meetings on even numbered months. If you do not have at least a Warminster Amateur Radio Club badge with your picture on it, please contact your Membership Chairs at the WARC monthly meetings. Otherwise, please contact Membership by email at: membership@k3dn.org.

If you want to have your picture taken to be placed on the 'Members' Photos' section of the www.k3dn.org website, please contact Membership with your interest. When we get enough people who are interested we will post a notice in Feedback and have a camera ready at the following club meeting.

PROGRAMS 2025

July - No Meeting

The Club Station - K3DN - is located at the Benjamin Wilson Senior Center, Delmont Avenue, Warminster, PA. The station is open for club members and the interested general public on the first Thursday of the month (meeting night) between the hours of 6:30 and 7:30 pm. with the exception of the December dinner meeting. The station is fully operational on HF (80 meters through 10 meters) both phone and CW. There is an assortment of amateur radio shareware which may be copied under the shareware licensing agreement.

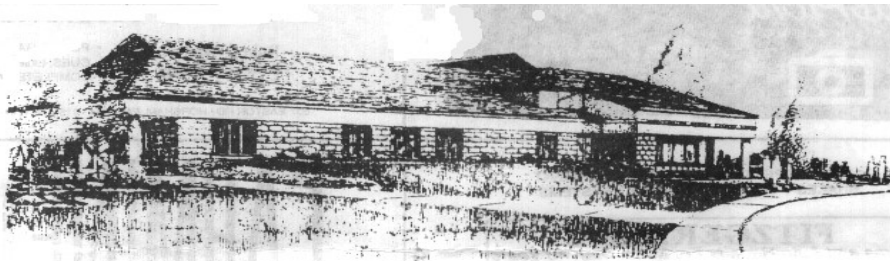

For additional information on the Club Station please call the Station Manager N3HBT - George at 215-443-5656.

➤ WARC Meetings are held the first Thursday of each month at 7:30 pm at the Benjamin Wilson Senior Center, Delmont Avenue, Warminster, PA. Talk in is available on the 147.09 & 443.950 repeaters.

SKYWARN INFORMATION

Bucks County SKYWARN Weather Spotter PRIMARY FREQUENCY: 147.300MHZ (+ 131.8)

Fairless Hills, PA (many remote access locations throughout Bucks County)

Mount Holly NWSFO SKYWARN Homepage:

<https://www.weather.gov/phi/Info>

SKYWARN Basic Weather Spotter Educational Programs URL:

<https://www.weather.gov/phi/classes>

➤ **CLUB EQUIPMENT**

WARC has 2 Baofeng UV-5R dual band HT's and a Yaesu FT-2900 2M mobile that are available for use by members of the club. The radios are available on a month-by-month basis and have been purchased primarily to help new hams get on the air. However, they may also be used by any club member who is in need of a temporary 2-meter radio. They are also available for use by participants in WARC's public service activities.
DE, Dave McGowan KC3RAT

Area Repeaters

VHF

- 145.310 R.F. Hill
- 145.350 Doylestown R.C.
- 146.790 Penn Wireless
- 145.330 Hilltown
- 146.670 DVRA
- 146.685 Holmesburg
- 146.925 Willingboro
- 147.000 Ham Bueggers
- 147.030 Phil-Mont
- 147.090 Warminster
- 147.270 Frankford
- 147.300 BEARS
- 147.390 CBRA

220

- 224.580 PackRats
- 223.76 K3NAL

UHF

- 442.650 DVRA
- 443.250 TAG
- 443.050 Metro-Comm
- 443.950 Warminster
- 444.200 BEARS
- 447.475 WR3B
- 448.225 Penn Wireless
- 444.759 RF Hill Analog/Fusion

D-STAR

- 146.61000 K3PDR DV
- 445.18125 K3PDR DV
- 445.01875 AA3E Montco RACES

6 Mtr

- 53.030 WA3BXW
- 53.230 N3DQZ
- 53.320 K3MFI

*The Warminster Amateur Radio Club
Announces Free Ham Radio Instructional Classes*



If you're interested in Ham Radio, or think you might be, this is your opportunity. Perhaps you'd like to learn about digital communications, VHF, UHF, satellite, or perhaps you'd rather sit down and chat with someone in South Africa, Russia, Great Britain or in the space station.

New Classes (Tech and General) to start Sept 13 from 7 pm to 9 pm.

For further information contact George Brechmann, N3HBT at 215-443-5656.

Bucks County Amateur Radio Emergency Service (BCARES)

www.bucksares.org

Bucks County ARES will be on the air Wednesdays, at 9:00 PM . We will be using Warminster Amateur Radio Club's repeater on 147.090, pl 131.8. This net is linked as shown in the Net Schedule box for the Wednesday night net. It may also be linked to 147.300.

Winlink Gateway Stations:

Lower Bucks NY3J-10 145.530 Bensalem

Net Schedules

Sunday	2000	10 Meter Net	28.445 MHz
Wednesday	2000	2 Meter Net	147.09 Rptr.
Wednesday	2000	Linked w/ 2 Meter Net	443.95
Rptr. Wednesday	2000	Linked w/ 2 Meter Net	53.230 Rptr.
Sunday	2030	Informal Net	223.5 Simplex
Thursday	1900	Mont. Cnty RACES Net	146.835 Rptr.

Are you submitting an article for the Feedback ?

Contributions of articles to be published are always accepted for consideration. Please follow these guidelines:

- E-Mail to:
wa4ywm@comcast.net
Or via snail mail to:
FEEDBACK EDITOR
Warminster Amateur Radio Club
Box 113
Warminster, Pa 18974
- Use both upper and lower case letters.
- Use your program's spell check.
- If you don't have a computer, then typewritten sheets are o.k, but please use both upper and lower case.
- Put your name and call at the beginning or end of the article, and show credits if you are using material from another source.
- Deadline for articles is the Saturday before the regular meeting.

For general club correspondence:

WARMrinfo@gmail.com

Visit our Home Page at:

<http://www.k3dn.org>

The annual dues rate structure is as follows:

Full Member: \$25.00
Student: \$ 7.50
Alumni: \$12.50

- Are your dues current ?

2025 Officers

Executive Officers

President	Dave McGowan	K3FTD	215-850-5846
Vice-President	Scott Vogin	KB3ALX	
Secretary	Tony Simek	N3YNH	215-796-0336
Treasurer	Tom Newman	K3PLA	215-630-5965
Director (A)	Doug Becker	KC3MNQ	215-932-1370
Director (E)	Herb Hickmott	KB3VMN	
Director (A)	Bruce Farrington	WA3ZPC	215-262-4215
Director (E)	George Brechmann	N3HBT	215-443-5656
Past President	Ray Oechslin	KA3TRU	267-269-3198

Committee Chairpersons

ARES/RACES Liason	Karl Harris	K3KH	215-264-1855
ARRL Liason			
Awards Manager	Vince Pironti	KD3TC	215-674-0446
Classes	Dave McGowan	KC3RAT	215-850-5846
	Dan Clementi	K3GMQ	267-337-0392
Digital and APRS	Ron Wenig	NY3J	215-638-9257
Feedback Editor	Jim Elmore	WA4YWM	215-538-1889
Field Day 25	Herb Hickmott	KB3VMN	267-718-3601
Hamfest 25	Tony Cuttone	W3FLH	267-679-9297
Hamwear	Kathy Acker	KC3FBY	215-815-7978
Holiday Dinner	George Brechmann	N3HBT	215-443-5656
Membership	Tony Cuttone	W3FLH	267-679-9297
Net Manager	George Brechmann	N3HBT	215-443-5656
PA QSO Party	Mark Kempisty	AA3K	
Publicity	Herb Hickmott	KB3VMN	267-718-3601
Refreshments	Arlene Newman	KA3PLA	215-345-4539
RF Interference	Bill Ballantine	K3FMQ	215-766-0764
Repeater Coordinator	Brian Taylor	N3EXA	215-257-6303
Safety Officer	Mike Malone	W3MJM	215-639-2175
Station Trustee	George Brechmann	N3HBT	215-443-5656
Good and Welfare			
Township Liason	George Brechmann	N3HBT	215-443-5656
VE License Testing	Larry Abbott	WA3ELQ	215-704-3282
VHF/UHF/MW	George Altemus	KA3WXV	215-855-3856
Website Coordinator	Kathy Acker	KC3FBY	215-815-7978
Youth Programs			